

Browse

Recent Submissions	Date	Author	Title	Subject	Affiliation (by Publication)	Affiliation (by Author)	Media Type	Publication Type	Area	Source Title	Publisher
--------------------	------	--------	-------	---------	------------------------------	-------------------------	------------	------------------	------	--------------	-----------

Now showing 1 - 5 of 9

Publication [Grikių lukštų ir durpių mišinių biokuro savybių tyrimas](#)

Research Article Steponavičiūtė, Miglė; Paulikiene, Simona

Agricultural engineering

Pasaulyje sparčiai mažėjant iškastinio kuro ištekliams, būtina ieškoti tvarių alternatyvų, kurios galėtų juos visiškai ar iš dalies pakeisti. Šiuo metu pastatams šildyti dažnai naudojami anglimi arba durpėmis kūrenami kieto kuro katilai. Siekiami apriboti durpių, kaip kietojo kuro, naudojimą, galime formuoti mišinius su žemės ūkio atliekomis. Grikių lukštai, kaip biokuras, pasižymi dideliu kaloringumu, mažu pelenų kiekiu ir aukšta pelenų lydymosi temperatūra, tačiau vien jų negalima sudeginti. Taip yra todėl, kad negalime granuliuoti grikių lukštų, nes juose nėra rišamųjų medžiagų. Norėdami naudoti grikių lukštus kaip biokurą, juos galime

12 3

Publication [Development of the methodology and substantiation of fuel supply parameters in the transition to biofuel](#)

Research Article Burlaka, Serhiy; Kupchuk, Ihor; Tverdokhlib, Ihor

Agricultural engineering

Changing the nature of the workflow of the diesel engine, increasing its technical and economic performance when converting to work on alternative fuels is pronounced when using mixed fuels. The differences between these properties of the components of different in both composition and ratio of fuels affect primarily the process of fuel supply, fuel spraying, evaporation and mixture formation. The article proposed a technique for reconfiguring the fuel supply system to operate on biofuel. Also, the parameters of the systems operation when using the F-22 injector were substantiated, at which the performance of the power system

3 1

Publication [Aktyviaja ventilacija džiovinamų pluoštinių kanapių samplio tyrimai](#)

Research Article Zvicevičius, Egidijus; Petronis, Šarūnas; Jonaitis, Martynas

Agricultural engineering

Pluoštinė kanapė (Cannabis sativa L.) – tai aukštaūgis vienmetis žolinis augalas turintis šakotą, apatinėje dalyje medėjantį stiebą. Tai produktyvus ir universalus augalas, kuris daugiausia yra vertinamas dėl pluošto ir sėklų. Pluoštinių kanapių sėklose yra 25–35 riebalų, 20–30 angliavandenių, 20–25 baltymų, daug mineralinių medžiagų. Dėl sėklose sukaupiamo gausaus kiekio polinesočiųjų riebalų rūgščių, ypač vertinamas kanapių aliejus. Tačiau dėl didelio sėklų drėgnumo ir riebalų kiekio, pluoštinių kanapių sėklų derliaus kokybės menkėjimo rizika yra didesnė nei javų grūdų. Siekiant išsaugoti jų kokybę, svarbu teisingai valdyti

5 2

Publication [Investigation of drive power of the mechanism for separation of stem feed from feed monolith](#)

Research Article Shargorodskiy, Serghiy; Rutkevych, Volodymyr; Kupchuk, Ihor; Hraniak, Valerij; Didyk, Andrii

Agricultural engineering

The article proposes a method of reducing the power of the drive for the separation of packages of canned feed from trench storage through the use of a modified hydraulic drive system. The structure and the principle of operation of the system of hydraulic drive of mechanisms of cutting of canned forages are developed. This approach has significantly reduced the power of hydraulic motors by simultaneously controlling the cutting speed of the monolith when feeding the rod and the feed rate of the cutting device. The substantiation of modes of operation of the mechanism and ways of increase of its energy

8 3

Publication [Use of vegetable oils as environmental additives in diesel fuel](#)

Research Article Burlaka, Serhiy; Yemchuk, Tetiana; Yelerych, Anatolij; Okhota, Yulia

Agricultural engineering

The relevance of this article is due to the need for wider distribution of alternative fuels for engines and the solution of growing environmental problems. Means and methods of reducing toxic emissions from exhaust gases of internal combustion engines are analyzed. The advantages and problems of using in the engines of alternative fuels derived from renewable raw materials, vegetable oils. The use of alternative motor fuels made from vegetable raw materials not only replaces the fuel of oil engines, but also reduces emissions of harmful substances into the exhaust gases of diesel fuel. Shows the workaround for the use of a m

21 9



Browse

Recent Submissions	Date	Author	Title	Subject	Affiliation (by Publication)	Affiliation (by Author)	Media Type	Publication Type	Area	Source Title	Publisher
--------------------	------	--------	-------	---------	------------------------------	-------------------------	------------	------------------	------	--------------	-----------

Now showing 6 - 9 of 9

Publication [Studying the dynamic characteristics of closed system of gravity concrete mixer's electric drive by means of computer simulation](#)

Research Article Shtut, Andrii; Kolsnyk, Mykola; Voznyak, Oleksandr

Agricultural engineering

Important tasks in the field of improving the quality of concrete and reinforced concrete products, increasing the level and pace of industrial development put serious demands on enterprises in terms of improving technical and economic performance, as well as a clearer and more efficient system of electrical equipment and energy saving. In this regard, the issues of efficient operation of existing equipment and improvement of its technological characteristics become especially important. On the other hand, improving and accelerating the process of construction production, raising it to a new level is possible only with high product

8 2

Publication [Study of the influence of technological parameters on the mechanics of shaping of billets using roll stamping processes](#)

Research Article Shtuts, Andrii; Kolsnyk, Mykola

Agricultural engineering

The article presents the results of development and research of technological schemes of planting flanges on tubular (ring) workpieces by stamping by rolling cylindrical and conical rolls. It is shown that the achievement of significant dimensions of the various elements of the workpiece is possible by providing a directed flow of metal by changing the relative position of the roll and the workpiece. Planting of external flanges is one of the most effective operations of stamping by rolling, as it allows you to form a wide range of products with advanced geometric elements. To assess the technological capabilities of the flange landing

4 2

Publication [Theoretical study of the change of the torque on the shaft of the feeding rotor of the shredding machine during the capture and compression of the grass mass](#)

Research Article Kholodiuk, Oleksandr; Hunko, Iryna; Kuzmenko, Volodymyr

Agricultural engineering

The shredding machine is any forage harvester's main and most energy-intensive unit. Its structural design determines the machine's technological scheme and the main units' location. Disc and drum shredders, which are equipped with trailed, haulage, and self-propelled forage harvesters, have become widespread. Biner-knife shredding machines are installed on pick-up trucks and balers. In general, the energy spent on grinding the grass mass includes components for grinding (compression, cutting, friction), transportation of the leaf-stem mass, as well as costs for the idling of the working bodies. A characteristic feature of the

12 1

Publication [Development of a single row animal drawn groundnut digger for smallholder groundnut farmers in Sudan Savannah of Nigeria](#)

Research Article Attanda, Muhammed Lawal; Abubakar, Mohammed Shu'aibu; Muhammad, Aliyu Idris; Adinoy, Aliyu

Agricultural engineering

Harvesting groundnut is a serious problem in the Sudan Savannah of Northern Nigeria. The small- and medium scale farmers harvest their groundnuts manually using traditional tools such as hoe. This practice is laborious, time-consuming, and leads to pod losses due to inefficient groundnut harvesting implement. In addition, the tractor-mounted groundnut harvesters are too expensive for these farmers to acquire. In view of the aforementioned, problems, a prototype of an animal-drawn groundnut digger was developed considering the agronomical and functional requirements for digging groundnut crops. The major compo

10 2



USE OF VEGETABLE OILS AS ENVIRONMENTAL ADDITIVES IN DIESEL FUEL

Serhiy Burlaka, Tetiana Yemchyk, Anatoliy Yelenych, Yuliia Okhota

Vinnitsia National Agrarian University, Ukraine

Abstract

The relevance of this article is due to the need for wider distribution of alternative fuels for engines and the solution of growing environmental problems. Means and methods of reducing toxic emissions from exhaust gases of internal combustion engines are analyzed. The advantages and problems of using in the engines of alternative fuels derived from renewable raw materials, vegetable oils. The use of alternative motor fuels made from vegetable raw materials not only replaces the fuel of oil engines, but also reduces emissions of harmful substances into the exhaust gases of diesel fuel. Shows the workaround for the use of a mixture of biofuels - a mixture of petroleum diesel fuel and vegetable oil.

Research aimed at optimizing the composition of such biofuels. Consider using a mixture of petroleum diesel fuel with linseed, mustard and sage oil. A method for optimizing these mixtures based on the definition of a generalized criterion of optimality, calculated as the sum of private standards characterizing the concentrations of normalized toxic components in exhaust gases, is proposed. Optimization calculations for the composition of biofuel diesel D-245.12C. The results showed that the exhaust gas toxicity of the engine improved as the content of these oils in the blend with petroleum diesel fuel increased, but even the addition of a small amount of vegetable oil to this fuel significantly improved these parameters. The minimum of the generalized optimal criterion was reached when using a mixture containing 91% of petroleum diesel fuel and 9% of linseed oil.

Keywords: *diesel engine, petroleum diesel fuel, linseed oil, mustard oil, safflower oil, blended biofuel.*

Received 2022-05-18, accepted 2022-06-29

1. Introduction

One of the main tasks of modern engine construction is to reduce emissions of harmful substances from exhaust gases (exhaust) of internal combustion engines [1, 2]. Indicators of VG toxicity include emissions of toxic components into the atmosphere, limited by modern regulations on the toxicity of VG engines. Normalized toxic components of diesel engines (hereinafter - diesels) are nitrogen oxides NO_x, carbon monoxide CO, light unburned hydrocarbons CH_x and solid particles based on carbon C (soot). Emissions of sulfur oxides SO_x are limited indirectly due to the sulfur content of 8 in the fuel. Dynamics of strengthening of requirements to the maintenance in VG of diesels of normalized toxic components is presented in fig. 1 and 2, as well as in table 1.

These data indicate the need for the introduction of engine tools and methods to reduce the toxicity of diesel engines. The development of measures to reduce the toxicity of VG can be carried out in the following main areas (Fig. 3) [4]: improving the design of the engine, taking into account operational factors and the use of alternative (non-traditional) fuels. From this point of view, biofuels with good environmental qualities are of special interest [5-7].

The aim of the study is to determine the efficiency of use of vegetable oils as environmental additives in diesel fuel and their impact on technical and economic performance of the machine unit.

2. Materials and Methods

Among the biofuels that are most widely used in diesels, we should highlight vegetable oils (PO) and their derivatives - methyl, ethyl and butyl esters [3, 7, 8].

Despite the problems that arise when operating diesels on RO, research continues on their work on

these biofuels and their mixtures with other fuels, mainly petroleum diesel fuel (DF) [8-9].



Fig. 1. Dynamics of the introduction in Europe of more stringent requirements for toxicity of HG engine

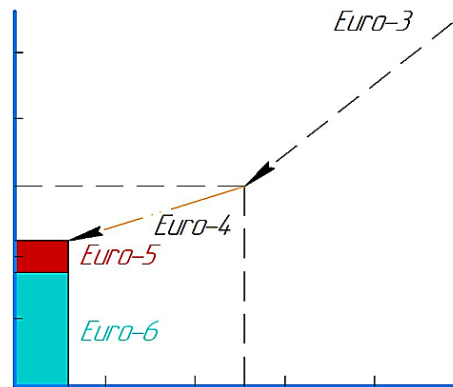

Fig. 2. Norms of harmful emissions from VG of diesel cars and passenger cars in the European test cycle (PM - solid particles, NO_x + CH_x - total emissions of nitrogen oxides and light unburned hydrocarbons)

Table 1. Requirements for limiting the content of harmful substances in the exhaust fumes of transport diesels in European countries

Standards for HCV toxicity	Maximum emissions of harmful substances from CO, mg/km		
	Nitrogen oxides	Solid particles	Carbon dioxide CO ₂
Euro-4	300	25	160...170
Euro-5	220	5	140
Euro-6	170	5	120

Analytical comparison of current European standards for internal combustion engines. Determining the effectiveness of using vegetable oils as additives is done experimentally using the D-245.12C engine and the KI-5542 loading stand, and the program for modeling the injection process and processing the DIESEL-RK results was also used.

3. Results and discussion

It should be noted that the use of rapeseed oil (RO) as a raw material for biofuels has little effect on the sector of their production for food purposes. Technical fuels obtained by extracting oilseeds or pre-squeezed cake with gasoline, hexane or other extractants can act as motor fuel. Low-quality and expired vegetable oils (VO) are suitable for technical use. Frying oils used for frying are a significant raw material base for biofuel production [10-12]. Oilseeds intended for the production of biofuels can be grown in areas unsuitable for food production (in areas with unfavorable environmental conditions, in areas adjacent to highways and industrial enterprises).

When using VO and their derivatives as motor fuel, there are two possible ways - centralized and decentralized production of biofuels [10, 12]. Centralized production of motor fuels with VO is the processing of VO into esters (methyl, ethyl, butyl), used in diesels or as stand-alone fuels, or in a mixture with petroleum. Decentralized production involves the use of "pure" VO or their mixtures with diesel fuel (DF). This direction is usually implemented directly in agro-industrial complexes, where there is a surplus of oils and biofuels can be carried out domestically from their own raw materials. This allows integrated use of agricultural products and reduce transportation costs.

The use of VO as an independent DF is difficult due to differences in physicochemical properties

of VO and petroleum DF. This is accompanied by problems that arise during the operation of diesels on the VO. These include the poor quality of the processes of fuel supply and spraying of oils caused by their high viscosity and density, as well as coking of sprays and parts that form the combustion chamber, impaired mobility of the piston rings. In this regard, it is advisable to use the VO as an environmental additive to oil DF [3, 8, 10, 15]. Mixtures of DF with a small addition of VO can solve these problems.

Rapeseed oil (RO) is usually considered when analyzing the possibilities of using different POs for biofuels [3, 8, 16]. At the same time, other types of VO are grown in Ukraine. The structure of production of VO in Ukraine is as follows: the share of sunflower oil (SO) in total VO production is 86.84%, soybean (SoyO)- 7.96%, rapeseed (RO)- 4.84%, mustard (MO) - 0.11%, residual oils (corn, flaxseed (FO), etc.) - 0.25% [15].

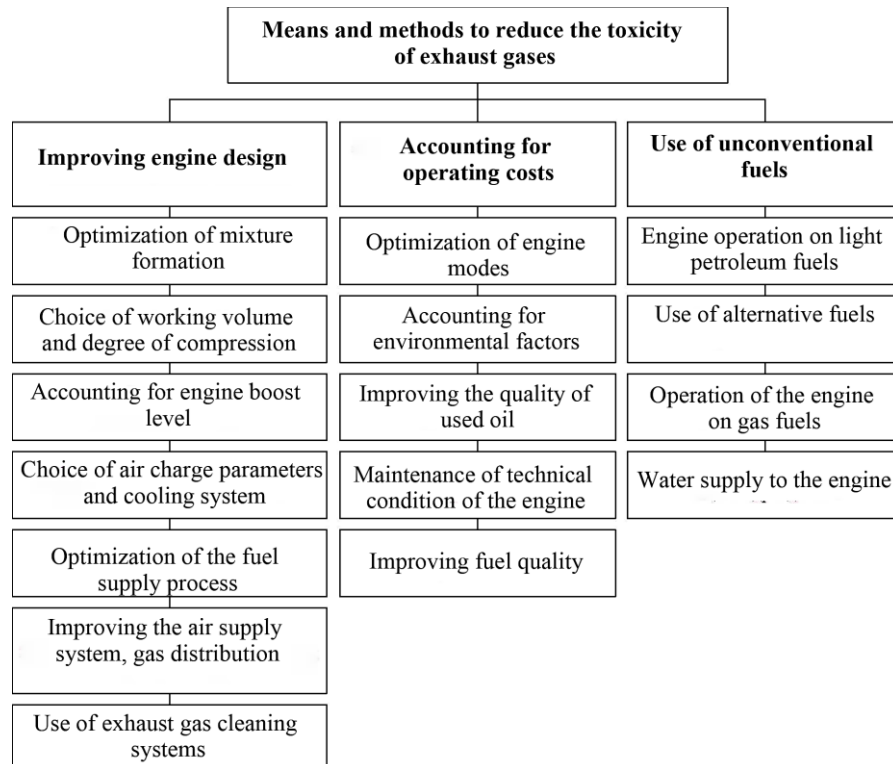

Fig. 3. The scheme of fixed assets and methods to reduce the toxicity of diesel exhaust

The purpose of the work is to evaluate the possibility of using flaxseed (FO), mustard (MO) and saffron (RizO) oils as an ecological additive to oil refinery. Articles [15] already present the results of a study of domestic tractor diesel on mixtures of petroleum DF with these oils. However, there is a need for comparative analysis of these data and optimization of the composition of such blended biofuels.

Flax is an annual (sometimes winter) plant of the flax family. Among them, the most famous are long flax (characterized by high quality fiber), curly flax (used mainly as an oil crop), and flax-mezheumok (oil-fiber culture).

Mustard is a plant of the cruciferous family, which includes such well-known crops as cabbage, radish, radish, turnip, canola and others. The family of cabbages also includes ore, which is an annual herb. This wild plant is very unpretentious, so it has long attracted the attention of breeders and today is successfully cultivated in the fields of Europe.

It should be noted that the physical and chemical properties of FO, MO and RizO are influenced by the variety of oilseeds, growing conditions and processing technology. At the same time, the properties of different VO, in many respects similar, depend on the composition and structure of fats, which, in turn, are determined by the type of plant. All fats are based on esters of glycerol and higher aliphatic acids [14, 15]. Many of these acids were first isolated from fats, so in the literature they are often called "fatty" acids. In the ester composition, one molecule of glycerol $C_3H(OH)$ is associated

with residues of three fatty acids, so such compounds are called triacylglycerides. The mass fraction of triacylglycerides in fats is 93 ... 98%. Other substances dissolved in fat and got into it in the process of oil production are called concomitant.

PMs contain mainly fatty acids with an even number of carbon atoms (C_{16} , C_{18} , etc.). In this case, the composition of VO includes both unsaturated (oleic, linoleic, linolenic, etc.) and saturated fatty acids (myristic, palmitic, stearic, etc.). In saturated fatty acids, the molecules do not have double bonds, and in unsaturated fatty acids there are one or three double bonds. The fatty acid composition of the oils of the main oilseeds of Russia are given in table 2. It should be noted that the oil content (mass content) of flax seeds (up to 50%), mustard (up to 45%) and ryzhik (up to 42%) can be compared with the oil content of sunflower seeds (up to 57%) and rapeseed (up to 50%).

Table 2. Fatty acid composition of various unrefined RO

VO	Mass fraction,% by weight, of fatty acids RO					
	Saturated			unsaturated		
	myristic C ₁₄ H ₂₈ O ₂ або C 14:0	palmitic C ₁₆ H ₃₂ O ₂ або C 16:0	Stearin C ₁₈ H ₃₆ O ₂ або C 18:0	oleic C ₁₈ H ₃₄ O ₂ або C 18:1	linoleum C ₁₈ H ₃₂ O ₂ або C 18:2	linolenic C ₁₈ H ₃₀ O ₂ або C 18:3
RO	0...0,2	5,6...7,6	2,7...6,5	14,0...39	18,3...74,0	До 0,3
SoyO	0...0,2	1,5...6,0	0,5...3,1	8,0...60,0	11,0...23,0	5,0...13
FO	5,4...11,3	2,5...8,0	0,4...1,0	13,0...36	8,3...30,0	30,0...67
MO	0...1,0	0,5...4,5	0,5...2,0	8,0...23,0	10,0...24,0	6,0
RizO	0...0,2	5,0...7,0	2,0...2,5	12,0...20	12,0...20,0	14,0...22

Note. The name of the fatty acid is followed by the formula of the composition and the conditional formula of the composition, in which the first digit corresponds to the number of carbon atoms, and the second - the number of double bonds in the molecule.

Table 3. Physico-chemical properties of the studied fuels

Property	Type of fuel									
	DF	FO	95% DF + 5% FO	91%DF + 10% FO	MO	95% DF + 5 % MO	90% DF + 10%MO	RizO	95 % DF + 5% RizO	90% DF + 10% RizO
Density at temperature 20 ° C, kg/m ³	830	912	834	837	920	835	839	910	834	838
Kinematic viscosity at a temperature of 20 ° C, mm ² /s	3,8	59,0	4,5	6,0	70,0	5,0	7,0	57,7	4,4	5,8
Heat of combustion нижча, МДж/кг	42,5	37,6	42,2	42,0	37,2	42,1	41,9	37,5	42,2	42,0
Cetane number	45	38	-	-	35	-	-	37	-	-
The amount of air required for combustion 1 kg of substance, kg of air/kg	14,31	12,62	14,23	14,16	12,44	14,19	14,11	12,52	14,23	14,13
Composition,% by weight: C H O	87,0 12,6 0,4	77,8 12,0 10,2	86,5 12,6 0,9	86,2 12,5 1,3	77,1 11,8 11,1	86,5 12,5 1,0	86,0 12,5 1,5	77,6 11,8 10,6	86,5 12,6 0,9	86,1 12,5 1,4

It should be noted that the fatty acid composition of FO, MO and RizO differs slightly from the similar composition of RO - the most common in Ukraine (see Table 2). One of the main differences

is that these oils contain more unsaturated fats acids. In particular, FO contains up to 67% by weight of linolenic acid, which has three unsaturated bonds, and MO - up to 0.3% by weight. In this regard, FO is less stable in oxidative processes than VO. Low oxidative stability (high oxidation) RizO causes its limited storage time. If the shelf life of unrefined RO is 38 weeks, unrefined FO is only 26 weeks. In this case, expired FO can be used as motor fuel.

In the table. 3 shows some physicochemical properties of LO, GO, RizO and oil DF brand L (summer) according to GOST 305-82. These data indicate that the physicochemical properties of RO differ markedly from petroleum. The cetane number of VO, which characterizes its spontaneous combustion in the combustion chamber (CS) of the diesel, is slightly lower than that of the oil DF.

In addition, VO is differ significantly from petroleum DF in fractional composition. The boiling point of VO is very high (about 280 ... 300 ° C against 180 ... 360 ° C in oil refineries). At atmospheric pressure and temperature more than 300 ° C it is impossible to disperse it into separate fractions because of thermal decomposition of oil.

One of the serious problems of using VO as a fuel for diesel engines is the increased viscosity of VO in comparison with that of oil refineries. This characteristic determines the quality of fuel spraying, mixture formation and subsequent combustion. The calorific value of VO is slightly lower than that of petroleum DF, because the molecules of these oils contain a significant number of oxygen atoms (up to 12% by weight, petroleum DF - 0.4% by weight).

In this regard, the specific specific consumption of VO is significantly higher than that of oil, with approximately equal efficiency of the combustion process (with approximately equal to the effective efficiency (efficiency) of the engine). At the same time, the content of significant amounts of oxygen in VO molecules, which promotes their oxidation during combustion, has a positive effect on the environmental properties of VO as a motor fuel. The positive environmental properties of VO include low sulfur content (0.002% vs. 0.2% in petroleum) and almost complete absence of polycyclic aromatic hydrocarbons, which are carcinogenic.

To assess the possibility of using the studied oils as an environmental additive to petroleum DF tests of diesel D-245.12C (4 CHN 11 / 12.5). This engine manufactured by the Minsk Motor Plant is installed on ZIL-5301 Bychok light trucks, and its modifications are installed on buses.

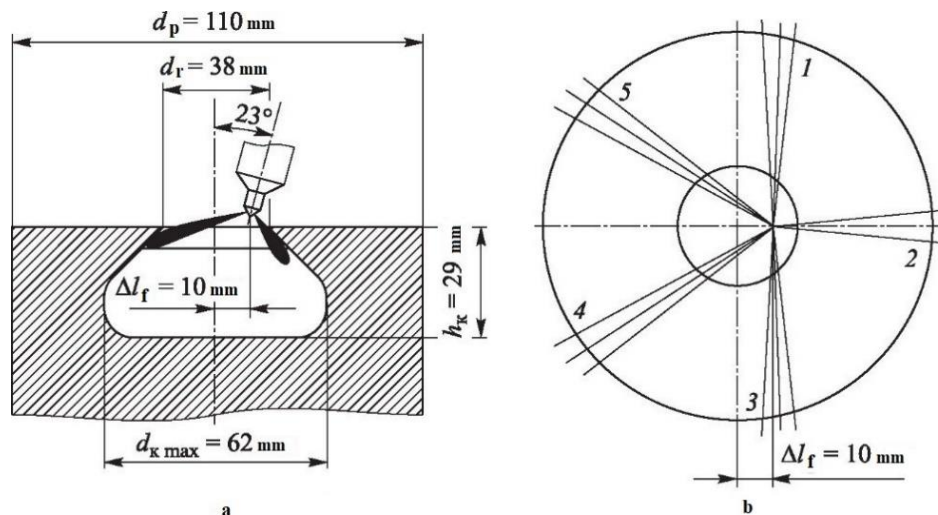

Fig. 4. Schemes of CS type CNIDI diesel D-245.12C with the layout of the injector (a) and the orientation of the jets (1-5) of the spray fuel in the CS (b): $d_{k \max}$ and N_k - the maximum diameter of the CS in the piston and its depth; d_n is the diameter of the piston; d_r is the diameter of the neck of the CS; D / f - removal of the nozzle relative to the axis of the CS

Pavlovsk Automobile Plant and tractors "Belarus" Minsk Tractor Plant. Mixtures of petroleum BF and with a small amount (up to 10% by volume) of different RO were studied. Some properties of these fuels are given in table 3 and the diagram of the diesel CS D-245.12C with the layout of the injector - in Fig. 4.

Table 4. Parameters of the D-245.12C diesel (4 ChN 11 / 12,5)

Engine type	Four-stroke, in-line, diesel
Number of cylinders	4
Cylinder diameter, mm	110
Piston stroke, mm	125
Total working volume, l	4,32
Degree of compression	16
Turbocharged	Turbocharger TKR-6
Short circuit type	CNIDI
The method of mixture formation	Volumetric film
Nominal speed, min-1	2400
Rated power, kW	80
Power supply system	Separate type
PNVT	in-line
Diameter of PNVT plungers	10
The course of plungers PNVT, mm	10
Length of injection fuel lines, mm	540
Nozzle type	FD-22
Injection start pressure, MPa	21,5

The motor stand is equipped with a set of necessary measuring equipment. Exhaust smoke was measured using a MK-3 opacimeter from Hartridge (UK) with a measurement error of $\pm 1\%$, and the concentration in the exhaust gas of nitrogen oxides NO_x, carbon monoxide CO, unburned light hydrocarbons, CH_x in the exhaust gas - gas analyzer SAE-7532 components $\pm 1\%$.

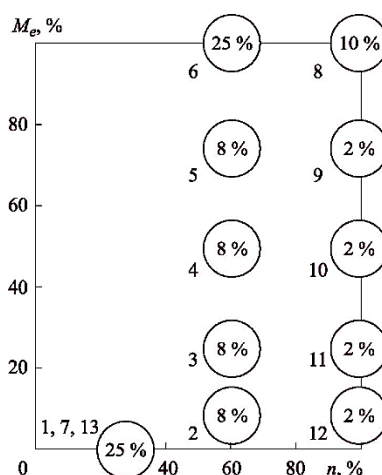

Fig. 5. Stationary European 13-mode cycle (ECE standard B.49), used to assess the toxicity of exhaust gases from diesel vehicles of medium and heavy capacity - with a gross weight of more than 3.5 tons (for each mode marked with a circle, its number is shown; circles the share of time of each mode in percent of total time of operation is resulted); M_e - torque on the engine shaft, which characterizes the loading mode of the diesel engine)

Diesel was tested in the external speed characteristics and 13-mode test cycle of ECE D49 of UNECE Regulation 49 (Euro-2) with an adjustable fuel injection advance angle of $\theta = 13^\circ$ crankshaft rotation to top dead center and constant position. This test cycle (Fig. 5) includes Indicators of diesel D-245.12C, running on oil DF and its mixtures with VO (13 established modes: three idle modes with minimum speed $n = (0.25 \dots 0.3) P_{nom}$, five load modes (10; 25; 50; 75; 100% load) at nominal frequency rotation P_{nom} and five load modes (10; 25; 50; 75; 100% load) at speed $n_+ (M_{max}) = 0.6 \dots 0.7 n_{nom}$, which corresponds to the maximum torque. The share of the nominal mode is 10% of the total operating time, and the share of the maximum torque mode is 25%. The results of experimental studies of the diesel engine are given in table 5.

Table 5. Physico-chemical properties of mixed fuels

Indicator	Fuel							
	DF	FO	95% DF + 5% FO	91% DF + 10% FO	MO	95% DF + 5% MO	90% DF + 10% MO	RizO
Hourly fuel consumption Century, kg / h	13,1	13,13	13,2	13,0	13,1	13,22	13,16	13,30
Diesel torque Me, Nm	322	321	319	321	321	318	318	317
Specific effective fuel consumption ge, g / (kWh)	248	250	252	248	250	253	252	253,
Effective diesel efficiency	0,34	0,340	0,34	0,34	0,34	0,339	0,338	0,338
Smoke OG KH,% on the Hartridge scale	16,0	12,0	11,0	17,0	15,0	12,0	16,0	15,0
Integrated 13-mode cycle modes (conditional) efficient engine performance: effective fuel consumption ge, g / (kWh)	247,97	248,72	252,26	244,6	247,17	251,08	250,22	255,57
Effective efficiency	0,341	0,343	0,340	0,346	0,346	0,342	0,341	0,335

Analysis of the results of experimental studies of diesel D-245.12C, running on oil DF and its mixtures with VO, shows that the task of choosing the optimal composition of blended biofuels is quite complex and has no clear solution. This is due to the fact that diesel operation is characterized by a set of indicators (criteria) of toxicity of exhaust fumes - normalized emissions of nitrogen oxides NO_x, carbon monoxide CO, light unburned hydrocarbons CH_x and solid particles or soot or soot (carbon) C (smoke). Requirements for choosing the optimal fuel composition according to these criteria often contradict each other. As a result, the task of choosing the optimal composition of blended biofuels becomes a multi-criteria optimization task [15].

There are various methods of solving multicriteria optimization problems, classified depending on the number of optimized parameters, the number of optimality criteria, the features of their problem and determine the degree of their significance. Regarding the problem of optimizing the composition of mixed fuels developed techniques described in [14, 15], which are based on one of the most effective methods optimization - a method of convolution, where the generalized criterion of optimality is formed as the sum of private criteria.

This paper proposes a method for optimizing the composition of blended biofuels - mixtures of petroleum DF with the studied VO, based on the preparation of a generalized additive criterion of optimality

$$I_o = a_{NO_x} J_{NO_x} + a_{CO} J_{CO} + a_{CH_x} J_{CH_x} + a_{K_x} J_{K_x} \quad (1)$$

where J_{NO_x} , J_{CO} , J_{CH_x} , J_{K_x} – private criteria of optimality for emissions of nitrogen oxides NO_x, carbon monoxide CO, light unburned hydrocarbons CH_x and soot C (smoke K_x); a_{NO_x} , a_{CO} , a_{CH_x} , a_{K_x} – weight coefficients of private optimality criteria.

These weights are selected taking into account the data of [4], in which the toxicological significance of toxic components of CO - NO_x, CO, CH_x, soot (smoke) is estimated as a ratio of 1: 41.1: 1: 3.16: 200. Given these data, expression (1) takes the form

$$I_o = 41,1 J_{NO_x} + 1,0 J_{CO} + 3,16 J_{CH_x} + 200 J_{K_x} \quad (2)$$

The particular optimality criteria included in expressions (1) and (2) are proposed to be determined for each mode using the ratios

$$J_{NO_x} = e_{NO_x} / e_{NO_x \text{ ДТ}}; J_{CO} = e_{CO_i} / e_{CO \text{ ДТ}} \quad (3)$$

$$J_{CH_x} = e_{CH_x i} / e_{CH_x \text{ ДТ}}; J_{K_x} = K_{x i} / K_{x \text{ ДТ}}$$

where $e_{NO_x i}, e_{CO_i}, e_{CH_x i}, K_{x i}$ – parameters of the diesel engine running on the i -th fuel; $e_{NO_x \text{ ДТ}}, e_{CO \text{ ДТ}}, e_{CH_x \text{ ДТ}}, K_{x \text{ ДТ}}$ – parameters of the diesel engine running on oil DF.

Expressions (1) and (2) use the values of integrated emissions of toxic components in the modes of the 13-mode test cycle of ESE D49 and the values of smoke in the mode of maximum torque of the external speed characteristic, which are the most critical. It is taken into account that the fuel efficiency of the studied diesel engine changes relatively slightly when the composition of the biofuels under consideration changes. In the transition from oil DF to its mixtures with a low content of CO₂ (up to 10%) conditionally effective efficiency of the diesel This mind in the 13-mode cycle changes within no more than 3% (see Table 4). Therefore, in the analysis of the properties of these fuels can be used generalized criterion of optimality, which takes into account only the indicators of CO toxicity. This generalized optimality criterion (2) is also convenient to use in relative form

$$J_0 = J_{0i} / J_{0 \text{ ДТ}} \quad (4)$$

Table 6. Optimization of the composition of mixtures of oil DF with RS for diesel D-245.12C

Type of fuel	e_{NO_x}	J_{NO_x}	e_{CO}	J_{CO}	e_{CH_x}	J_{CH_x}	K_x	J_{K_x}	J_0	J_0
Mixtures of oil DF with FO										
DF	7,018	1,000	1,723	1,000	0,748	1,000	43,0	1,000	245,26	1,000
95% DF + 5% FO	6,230	0,888	1,631	0,947	0,695	0,929	37,5	0,872	214,78	0,876
91% DF + 9% FO	6,441	0,918	1,511	0,877	0,664	0,888	36,0	0,837	208,81	0,851
Mixtures of oil DF with MO										
DF	5,911	1,000	2,184	1,000	0,675	1,000	42,0	1,000	245,26	1,000
95% DF + 5% MO	5,760	0,974	2,140	0,980	0,602	0,892	38,0	0,905	224,83	0,917
90% DF + 10% MO	5,689	0,962	2,068	0,947	0,561	0,831	36,0	0,857	214,5	0,875
Mixtures of oil DF with RizO										
DF	5,911	1,000	2,184	1,000	0,675	1,000	42,0	1,000	245,26	1,000
95% DF + 5% RizO	5,783	0,978	2,127	0,974	0,660	0,978	39,0	0,929	230,06	0,938
90% DF + 10% RizO	5,341	0,904	1,853	0,848	0,585	0,867	37,5	0,893	219,3	0,894

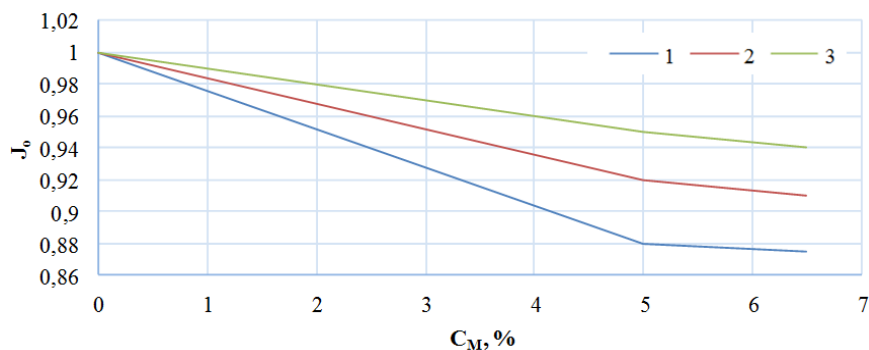

Fig. 6. Dependence of the generalized optimality criterion J_0 on the volume content of flaxseed (1), mustard (2) and saffron (3) oils in a mixture with petroleum DF

When solving the optimization problem using expressions (2) and (4), the generalized optimality criterion is minimized.

The proposed technique is used to optimize the composition of mixtures of petroleum DF with VO (FO, MO, RizO) in diesel D-245.12C. This used the experimental data of table 4. The results of the calculation of particular optimality criteria for expressions (3) and the generalized optimality criterion for formulas (2) and (4) are given in table 5.

The optimization results indicate that for the diesel D-245.12C running on the studied mixtures, the values of the generalized optimality criterion j_o monotonically decrease with increasing content of oils under consideration in the mixture with oil DF. Working on oil DF, the generalized criterion j_o is equal to one, and the minimum value of the generalized optimality criterion (j_o about = 0.851) is achieved when using a mixture of 91% oil DF and 9% RizO.

It is noteworthy that as the content of VO in the mixture with petroleum DF increases, the generalized criterion of optimality j_o constantly decreases, but its decrease is most noticeable at low content of VO in the mixed biofuel (see Fig. 5). In particular, when converting diesel D-245.12C from oil DF to a mixture of 95% DF + 5% RizO, the generalized optimality criterion decreases from 1.000 to 0.876, and a further increase in CM to 9% leads to a decrease of only 0.851. This indicates that even a small addition of vegetable oil to the oil DF significantly improves the toxicity of the exhaust gas of the studied diesel.

4. Conclusions

1. The expediency of using VO as an ecological additive to oil DF is shown. Mixtures of oil DF with flaxseed, mustard and saffron oils are considered.

2. Analysis of test results of diesel D-245.12C on mixtures of petroleum DF with these oils confirmed the possibility of improving the toxicity of exhaust fumes - reducing emissions of all normalized toxic components of exhaust fumes: nitrogen oxides, carbon monoxide, unburned light hydrocarbons, smoke fumes.

3. A method for optimizing the composition of mixtures of VO with DF, based on the definition of a generalized criterion of optimality in the form of the sum of private optimality criteria that characterize the emissions of normalized toxic components of diesel exhaust.

4. The results of optimization indicate that for the diesel D-245.12C, working on the studied mixtures, with increasing content of VO in the mixture with oil DF generalized criterion of optimality decreases monotonically. Its minimum value $J_0 = 0.851$ was achieved using a mixture of 91% petroleum DF and 9% RizO. Even a small addition of VO to the DF significantly improves the toxicity of the exhaust of this diesel.

5. The research confirmed the effectiveness of the proposed method of optimizing the composition of blended biofuels, its informativeness in assessing the environmental qualities of blended fuels of different composition and a relatively small amount of calculations.

6. The results of research allow us to conclude that the effectiveness of mixtures of petroleum DF with RO in diesels for various purposes. First of all, these are engines of agricultural machines, which can use mixtures of petroleum BF with technical, low-grade, expired and frying oils.

5. Funding

This research was supported and funded by the Ministry of Education and Science of Ukraine under grant № 0122U000844.

References

- [1] Kaletnik G., Honcharuk I., Okhota Yu. The Waste-Free Production Development for the Energy Autonomy Formation of Ukrainian Agricultural Enterprises. Journal of Environmental Management and Tourism. 2020. Vol. 11, № 3 (43). P. 513-522. DOI: 10.14505/jemt.v11.3(43).02. URL: <https://journals.aserspublishing.eu/jemt/article/view/4996>.
- [2] Охота Ю.В., Козак К.В. Основні тенденції ефективного використання біогазу в Україні. Ефективна економіка. 2018. № 4. URL: <http://www.economy.nayka.com.ua/?op=1&z=6264>.

- [3] A. Morozova “Modern trends in agriculture Ukraine” in AGROWORLD, no. 3, 2013, pp. 3-9
- [4] S. Hrushetskyi, V. Yaropud, I. Kupchuk and R. Semenyshena (2021) “The heap parts movement on the shareboard surface of the potato harvesting machine” in Bulletin of the Transilvania University of Braşov. Series II: Forestry, Wood Industry, Agricultural Food Engineering, vol. 14 (63), No 1, 2021, pp. 127-140. Doi: 10.31926/but.fwiafe.2021.14.63.1.12
- [5] N. Reznik Theory of cutting with a blade and the basics of calculating the cutting apparatus. Moscow: Mashinostroenie, 1975.
- [6] V.F. Hraniak, V.V. Kukharchuk, V.V. Bogachuk, Y. G. Vedmitskyi, I.V. Vishtak, P. Popiel, and G. Yerkeldessova “Phase noncontact method and procedure for measurement of axial displacement of electric machine’s rotor” in Proc. SPIE 10808, Photonics Applications in Astronomy, Communications, Industry, and High-Energy Physics Experiments, 2018, 7 p. Doi: 10.1117/12.2501611
- [7] V.S. Rutkevych “The current state of mechanization of unloading of canned food” in Collection of scientific works of VNAU, no. 4, 2010, pp. 87-95.
- [8] V.S. Rutkevych “Adaptive hydraulic drive block-portable of canned forage block-batch separator” in Engineering, power engineering, transport of agroindustrial complexes, no. 4, 2017, pp. 108-113.
- [9] V.P. Horiachkin Collection of works. In 3 vols. Vol. 3. Theory of straw chopper and silage cutter. Moskva: Kolos, 1968.
- [10] D.G. Voitiuk, S.S. Ytsun, and M.Y. Dovzhyk Agricultural machines: the basics of theory and calculation. Sumy: VTD “Universytetska knyga”, 2008.
- [11] V.A. Zhelihovskii Experimental theory of blade cutting. Moskva: Trudy MIMESKh, 2013.
- [12] V.P. Yanovich and I.M. Kupchuk (2017) “Determination of rational operating parameters for a vibrating dysk-type grinder used in ethanol industry” in INMATEH – Agricultural Engineering, vol. 52, No. 2., 2017, pp. 143–148.
- [13] O. Tsarenko, S. Yatsun, M. Dovzhik and G. Oliynik Mechanical and technological properties of agricultural materials. Kyiv: Ahrarna, 2016.
- [14] V.F. Kuzmenko, S.M. Yampolskyi and V.V. Maksimenko “Experimental determination of fractional composition of corn mass during silage preparation in late terms” in Mechanization and electrification of agriculture: intersectionality. theme. of sciences, vol. 99, 2014, pp. 559-568.
- [15] V.F. Dubinin Substantiation of processes and means of loading of objects of agricultural production. Extended abstract of candidates thesis. Moskva, 1994.
- [16] I.M. Pavlov Improvement of technological process and substantiation of parameters of a working body of the loader for block excavation of canned forages from trench storages. Extended abstract of candidates thesis. Saratov, 1990.
- [17] M.I. Ivanov, O.M. Pereiaslavskyi, V.S. Rutkevych, M.V. Ziniev and A.I. Sharyi The hydraulic drive of the block-portion separator of canned forages. UA Patent No. 80958, 2013.
- [18] Y.G. Vedmitskyi, V.V. Kukharchuk, V. F.Hraniak, I.V. Vishtak, P. Kacejko, and A. Abenov “Newton binomial in the generalized Cauchy problem as exemplified by electrical systems” in Proc. SPIE 10808, Photonics Applications in Astronomy, Communications, Industry, and High-Energy Physics Experiments, 2018, 7 p. Doi: 10.1117/12.2501600

Author Contacts:

BURLAKA Serhiy, PhD of Engineering, Senior Lecturer,
Faculty of Engineering and Technology, Vinnytsia National Agrarian University
21008, 3 Sonyachna str., Vinnytsia, Ukraine,
e-mail: ipserhiy@gmail.com,
ORCID ID: 0000-0002-4079-4867.

YEMCHYK Tetiana, PhD in Economics, Associate Professor,
Faculty of Management and Law, Vinnytsia National Agrarian University
21008, 3 Sonyachna str., Vinnytsia, Ukraine,
phone: +380961224202; e-mail: tana.honcharuk@gmail.com),
ORCID ID: 0000-0001-6998-4325.

OKHOTA Yuliia, PhD in Economics, Assistant,
Faculty of Management and Law, Vinnytsia National Agrarian University
21008, 3 Sonyachna str., Vinnytsia, Ukraine,
phone: +380637497218; e-mail: yuliaokhota2017@gmail.com),
ORCID ID: 0000-0001-9943-2206.

Person for contacts: Ihor Kupchuk, Vinnytsia National Agrarian University, E-mail: kupchuk.igor@i.ua